

# Talk Modern:

## Stories to Build a Modern Vocabulary

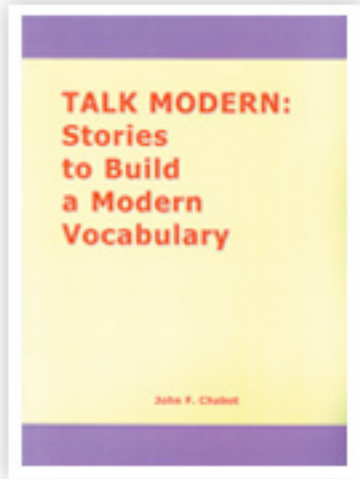

*Stories to Build a Modern Vocabulary* is a 30 unit reproducible reading and discussion text for Intermediate to Advanced students. There are ten articles on modern technology, ten articles about the way we live, and ten articles on problems faced by society. Each story is accompanied by several exercises covering most skill areas.

One of the primary aims of *TALK MODERN: Stories to Build a Modern Vocabulary* is to promote a problem-solving approach to vocabulary learning. On their first encounter with the reading passages, students should be encouraged to work out the solutions to the exercises with limited teacher guidance. After initial attempts to complete the exercises use of a dictionary is encouraged.

- Intermediate to Advanced levels**
- Suitable for teens and adults**
- 360 pages**

**Note: This is a non-printable sample. To purchase and download the complete eBook, select the “Add to Cart” button on our eBook main page.**

**For more information on this or any of our other eBooks, write to [info@esl-library.com](mailto:info@esl-library.com).**

TALK MODERN:  
Stories to Build a  
Modern Vocabulary



## TABLE OF CONTENTS

page	title	
1	Blogging	
5	Forensics	
9	SPAM	
13	Hybrid Engines	<b>TECHNOLOGY</b>
17	Satellite Television	
21	Spyware	
25	Search Engines	
29	Long Distance Surgery	
33	Biofuels	
37	eBay	
41	Human Smuggling	
45	Bullying	
49	Identity Theft	
53	Divorce	<b>MODERN ISSUES</b>
57	Obesity	
61	Gangs	
65	Homelessness	
69	Cloning	
73	Aging Populations	
77	Bipolar Disorder	
81	Diet Fads	
85	Banning Certain Breeds of Dogs	
89	Reality Television	
93	Aromatherapy	<b>MODERN TIMES</b>
97	Psychics	
101	Poker	
105	Class Action Lawsuits	
109	Trans Fat	
113	Paparazzi	
117	Weather Patterns	

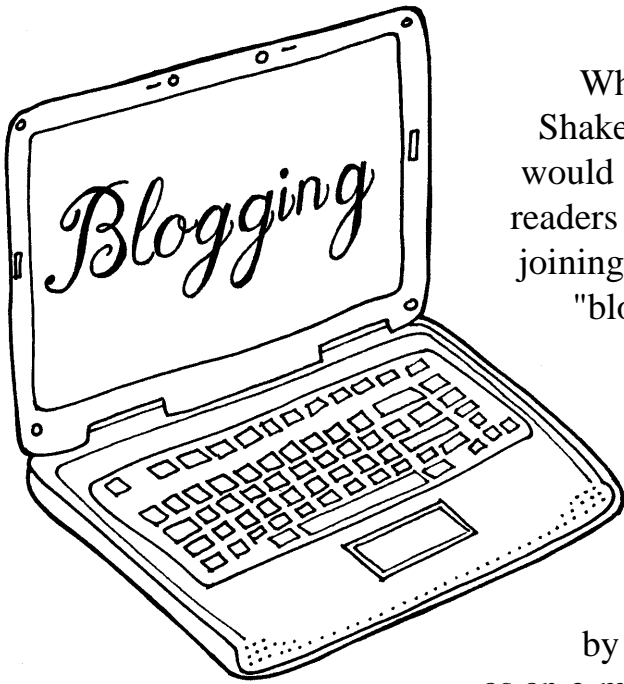

Where would world-famous playwright William Shakespeare be if he were alive today? Chances are he would be sitting at his personal computer entertaining readers with his very own *blog*. Mr. Shakespeare would be joining millions of other writers who have discovered "blogging," the newest form of expression on the Internet.

Blogs are sometimes referred to as *web logs* or *weblogs*. However, the term "blog" is the name most commonly preferred by Internet users. Defining exactly what a blog is can be difficult.

Simply put, a blog is writing published on the web by its author. The content of a blog can be as informal as an e-mail created by a writer for friends and family to view on-line. Blogs can also be articles reporting on news stories, essays discussing societal issues or opinion pieces expressing personal political views. The fact is, there are as many unique forms of blogs being published on-line as there are people writing them!

Amateur writers maintained blogs on the web long before the term became popular with mainstream computer users. However, the trend really started to gain momentum with the introduction of automated publishing systems. Millions of people now use services such as Blogger to help with their on-line publications. Blogger is a free web-based service that helps interested writers publish blogs on the web. With the click of a mouse and a few key strokes even a novice can attract readers from across the globe. The growth in on-line publishing has begun to change the way people share news, information, opinions and ideas. Some of the most popular weblogs are ones that invite reader feedback through interactive discussion forums.

The majority of bloggers are people looking for an outlet to express their thoughts and share them with others. However, professional lobbyists and political activists have discovered that writing blogs is an effective way to generate interest in their causes. In a world where giant companies control so much of the information people receive through the media, many people see blogging as a way to ensure that a variety of ideas can be communicated around the world.

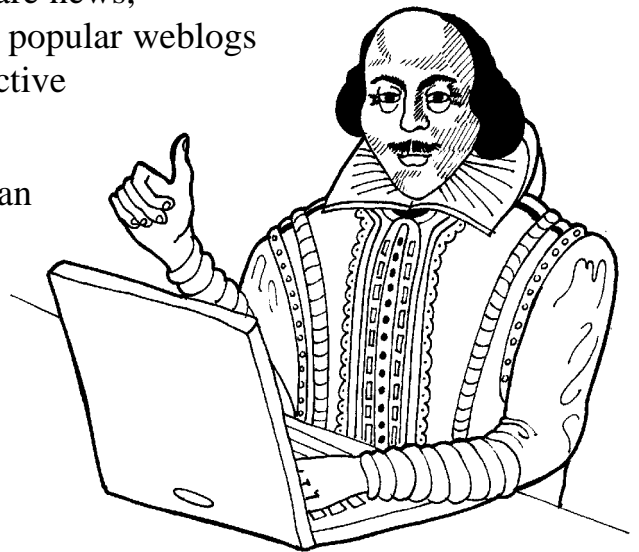

## EXERCISE 1

What is the main idea of this story?

- a) Shakespeare's use of the Internet.
- b) The increase in the amount of news found on-line.
- c) Popular weblogs.
- d) Defining blogs and all their uses on the Internet.

## EXERCISE 2

Circle the correct answer.

1) What exactly is a blog?

- a) Writing published on-line.
- b) A place where writers meet.
- c) A way for governments to control media.
- d) A home for political activists.

2) What have professional lobbyists and political activists discovered about blogs?

- a) They can get paid for writing them.
- b) Blogs are very funny to read.
- c) Blogs are more important than the media.
- d) Blogs are a good way to generate interest.

## EXERCISE 3

Below are five sentences. Each contains a blank. Fill in the blank.

- 1) However, the term "blog" is the name most \_\_\_\_\_ preferred by Internet users.
- 2) The fact is, there are as many unique forms of blogs being \_\_\_\_\_ on-line as there are people writing them.
- 3) The \_\_\_\_\_ of bloggers are simply people looking for an outlet to express their thoughts and share them with others.
- 4) With a click of a \_\_\_\_\_ and a few key strokes even a novice can attract readers from across the globe.
- 5) Some of the most popular weblogs are ones that invite reader \_\_\_\_\_ through interactive discussion forums.

## EXERCISE 4

Words on the left are words from this unit. Draw a line to the word on the right with the closest meaning.

- |               |             |
|---------------|-------------|
| 1) playwright | a) amateur  |
| 2) essays     | b) articles |
| 3) novice     | c) means    |
| 4) outlet     | d) comment  |
| 5) feedback   | e) author   |

## EXERCISE 5

Based on the article, circle the letter of the best sentence completion.

- 1) Automated on-line publishing systems have made it possible
  - a) for uneducated people to begin publishing careers.
  - b) for millions of people to begin publishing blogs on the web.
  - c) for computer makers to sell more computers.
  - d) for anyone to read your e-mail without your knowledge.
- 2) Blogging on the Internet has helped people around the world
  - a) find out the latest scores of football and hockey games.
  - b) discover that other countries have computers outside of the United States.
  - c) share news, information, opinions and ideas.
  - d) discover the writings of William Shakespeare.

## EXERCISE 6

Write TRUE or FALSE under each statement. If the statement is false, write the statement correctly.

- 1) Blogs are sometimes referred to as web logs or weblogs.  
\_\_\_\_\_
- 2) The content of a blog can only include real news stories.  
\_\_\_\_\_
- 3) Dozens of people now use services such as Blogger to help with their on-line publications.  
\_\_\_\_\_
- 4) Professional lobbyists and political activists have found that writing blogs is a waste of time.  
\_\_\_\_\_

## EXERCISE 7

Match each word in the box with its definition below:

- a) informal    b) opinion    c) automated    d) majority    e) giant    f) ensure

- 1) \_\_\_\_\_ view
- 2) \_\_\_\_\_ greater part
- 3) \_\_\_\_\_ massive
- 4) \_\_\_\_\_ mechanical
- 5) \_\_\_\_\_ casual
- 6) \_\_\_\_\_ guarantee

# ANSWER KEY

## EXERCISE 1

d) Defining blogs and all their uses on the Internet

## EXERCISE 2

- 1) a
- 2) d

## EXERCISE 3

- 1) commonly
- 2) published
- 3) majority
- 4) mouse
- 5) feedback

## EXERCISE 4

- 1) e
- 2) b
- 3) a
- 4) c
- 5) d

## EXERCISE 5

- 1) b
- 2) c

## EXERCISE 6

- 1) True
- 2) False. The content of a blog can be as informal as an e-mail created by a writer for friends and family to view on-line. Blogs can also be articles reporting on news stories, essays discussing societal issues or opinion pieces expressing personal political views. The fact is, there are as many unique forms of blogs being published on-line as there are people writing them!
- 3) False. Millions of people now use services such as Blogger to help with their on-line publications.
- 4) False. Professional lobbyists and political activists have discovered that writing blogs is an effective way to generate interest in their causes.

## EXERCISE 7

- 1) b
- 2) d
- 3) e
- 4) c
- 5) a
- 6) f

# AGING POPULATION

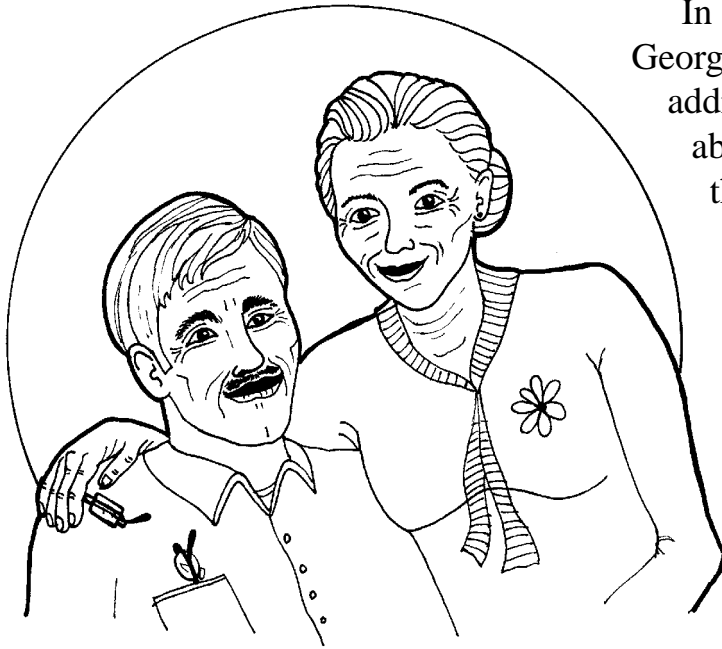

In the summer of 2005 United States president George W. Bush delivered his State of the Union address. In his speech he informed Americans about the financial problems being faced by the country's Social Security program. Many economists in the U.S. welcomed the message. For years the economists had been warning about the effects an aging population would have on the American economy.

Estimates by the Congressional Budget Office suggest that federal spending on the elderly will grow to more than \$1 trillion by 2010. That is up from \$615 billion spent only a decade earlier. Some

economists predict that by the year 2015 spending on the elderly will equal nearly half the entire U.S. federal budget. Most of this money will be directed into such programs as Medicare, Medicaid, pensions for federal workers and retired military staff, veterans health care and pensions, food stamps, plus assistance programs for heating and housing.

In contrast, federal spending on children in 2010 is expected to be around \$230 billion. This represents less than 10 percent of the U.S. federal budget. Why will there be such a huge gap between spending on the elderly and spending on children? The answer lies in the numbers. In the year 2000 around 10 percent of U.S. citizens were over 64 years of age. By 2010 it will be closer to 15 percent. By 2040 that number is expected to climb to over 20 percent. Improvements in medicine, health care and diet mean people are simply living longer. Maintaining programs for an aging population costs money.

Not everyone believes so much of the U.S. budget should be spent on the elderly. Since 1975, the income of people age 65 and older has risen by one-third. At the same time, people age 45 and under are earning about the same or less than before. Many people are questioning whether age alone should determine whether a person gets access to public money and tax breaks.

The problem is not unique to the United States. In Japan, Germany, Italy, Spain and China aging populations will have a large effect on the future. The size and shape of government budgets, living standards and the stability of the global economy will all be affected by the world's aging population.

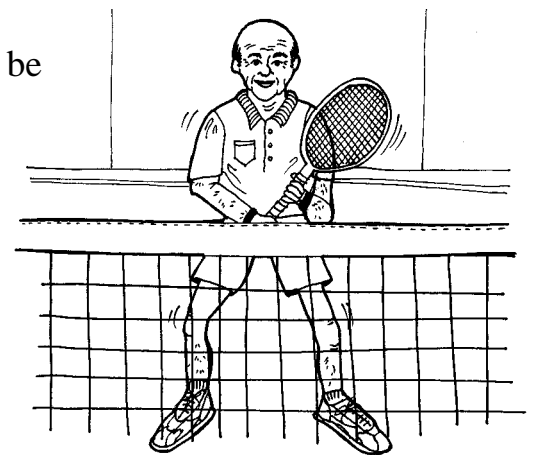

## EXERCISE 1

What is the main idea of this story?

- a) Spending on the elderly.
- b) Consequences of an aging population.
- c) Rising incomes of the elderly.
- d) Social Security fraud in the United States.

## EXERCISE 2

Circle the correct answer without looking back at the story.

1) Around what percentage of U.S. citizens were over age 64 in the year 2000?

- a) 15.
- b) 10.
- c) 65.
- d) 20.

2) Which other countries are mentioned as having aging populations?

- a) Japan, Italy, Germany, Spain, Russia.
- b) Japan, Italy, Germany, France, China.
- c) Japan, Italy, Germany, Spain, China.
- d) Canada, Italy, Germany, Spain, Korea.

## EXERCISE 3

Below are five sentences. Each contains a blank. Fill in the blank by using the appropriate word from this unit.

- 1) Many economists in the U.S. \_\_\_\_\_ the message.
- 2) Some \_\_\_\_\_ predict that by the year 2015 spending on the elderly will equal nearly half the entire U.S. federal budget.
- 3) \_\_\_\_\_ programs for an aging population costs money.
- 4) Many people are \_\_\_\_\_ whether age alone should determine whether a person gets access to public money and tax breaks.
- 5) The problem is not \_\_\_\_\_ to the United States.

## EXERCISE 4

Words on the left are words from this unit. Draw a line to the word on the right with the closest meaning.

- 1) message
- 2) spending
- 3) answer
- 4) risen
- 5) stability
- a) gone up
- b) information
- c) expenses
- d) permanence
- e) solution

## EXERCISE 5

Based on the article, circle the letter of the best sentence completion.

- 1) As a result of an increasing number of older people
  - a) people will have to pay more money to maintain their current level of service.
  - b) government spending on seniors will increase.
  - c) young people will enjoy free services as they age.
  - d) veterans will be given government grants to pay for medicine.
  
- 2) Since 1975, the income of people age 65 and over
  - a) has decreased by over 50 percent.
  - b) has risen by one-third.
  - c) has been heavily taxed by all levels of government.
  - d) has been eroded by the high cost of living.

## EXERCISE 6

Write TRUE or FALSE under each statement. If the statement is false, write the statement correctly.

- 1) In the summer of 2005 U.S. President George W. Bush delivered his State of the Union address.  

---
  
- 2) Some economists predict that by the year 2015 spending on the elderly will equal nearly ten percent of the entire U.S. federal budget.  

---
  
- 3) Everyone believes so much of the U.S. budget should be spent on the elderly.  

---
  
- 4) The problem of an aging population is unique to the United States.  

---

## EXERCISE 7

Match each word in the box with its definition below:

a) decade    b) budget    c) elderly    d) diet    e) global    f) population

- 1) \_\_\_\_\_ financial plan
- 2) \_\_\_\_\_ citizens of a country
- 3) \_\_\_\_\_ older people
- 4) \_\_\_\_\_ worldwide
- 5) \_\_\_\_\_ period of ten years
- 6) \_\_\_\_\_ daily food intake

# ANSWER KEY

## EXERCISE 1

b) Consequences of an aging population.

## EXERCISE 2

- 1) b
- 2) c

## EXERCISE 3

- 1) welcomed
- 2) economists
- 3) Maintaining
- 4) questioning
- 5) unique

## EXERCISE 4

- 1) b
- 2) c
- 3) e
- 4) a
- 5) d

## EXERCISE 5

- 1) b
- 2) b

## EXERCISE 6

- 1) True
- 2) False. Some economists predict that by the year 2015 spending on the elderly will equal nearly half (50 percent) the entire U.S. federal budget.
- 3) False. Not everyone believes so much of the U.S. budget should be spent on the elderly.
- 4) False. The problem of an aging population is not unique to the United States.

## EXERCISE 7

- 1) b
- 2) f
- 3) c
- 4) e
- 5) a
- 6) d

# PAPARAZZI

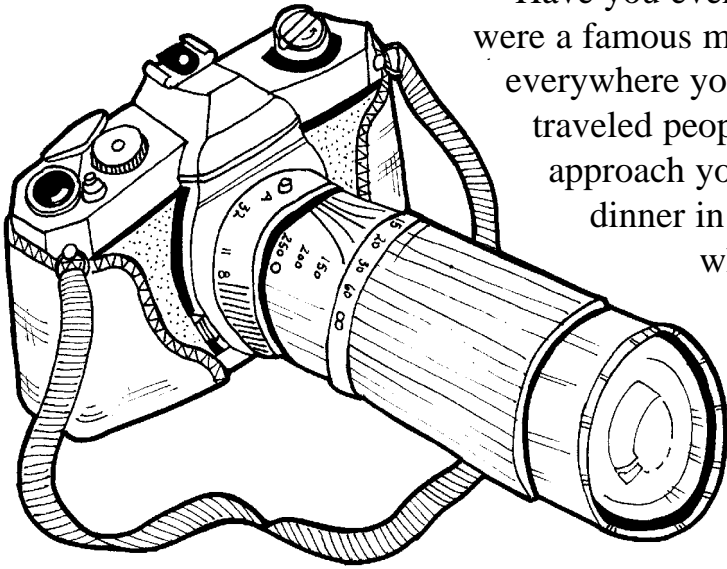

Have you ever dreamed of being rich and famous? If you were a famous movie star people would recognize you everywhere you went. No matter where in the world you traveled people would know who you were. They might approach you for autographs while you were enjoying dinner in a restaurant. They might follow you around when you went shopping. They might even go through your garbage in order to get things that belonged to you.

There are many reasons why people enjoy being rich and famous. The things listed above are some of the reasons people dislike being rich and famous. The number one complaint people have about fame is the loss of privacy that results when they become famous. Famous people have a difficult time leading normal lives because everyone knows who they are. Magazines and newspapers regularly print stories with information about their private lives. And many famous people become targets of the *paparazzi*.

The word "paparazzi" was originally used to describe photographers in Italy who made their living selling pictures of celebrities. These pictures often showed celebrities doing something they might not want to have photographed. Paparazzi can now be found throughout the world wherever celebrities gather. The term has become more commonly used as a negative way to describe photographers who stalk these celebrities to take their picture.

Improved camera equipment, long lenses and high-speed films have made it easier for paparazzi to take pictures of celebrities from a distance. Digital technology has also made it easier to send pictures around the world. Often victims of paparazzi do not even know they are being photographed. Many are shocked and surprised when they see their private lives on display through pictures in the media.

When Princess Diana was killed in a car crash it was reported that she was fleeing paparazzi trying to take her picture. The world was outraged. As a result many countries took action against the paparazzi. Some passed laws and curfews that restricted the freedoms enjoyed by celebrity photographers. That was good news for the celebrities around the world who long to enjoy a moment of privacy.

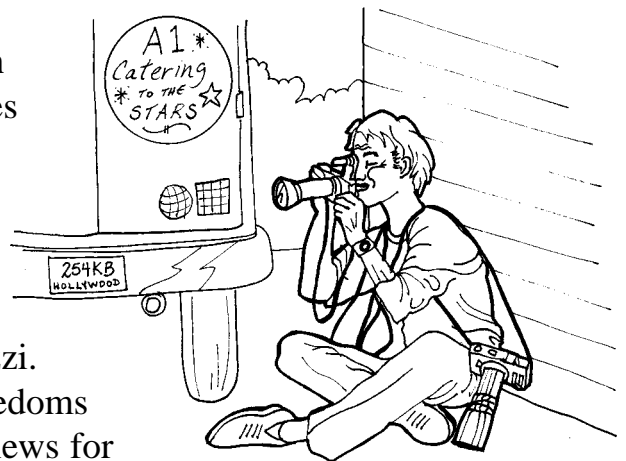

## EXERCISE 1

There are five paragraphs in this essay. Choose the sentence that best summarizes each paragraph. Match the paragraph with the right letter.

Paragraph 1 talks about \_\_\_\_\_

Paragraph 4 talks about \_\_\_\_\_

Paragraph 2 talks about \_\_\_\_\_

Paragraph 5 talks about \_\_\_\_\_

Paragraph 3 talks about \_\_\_\_\_

- a) Reasons to dislike being famous.
- b) Modern tools of the paparazzi.
- c) Paparazzi and the law.
- d) What happens if you become famous.
- e) The definition of "paparazzi."

## EXERCISE 2

Look at the two words. Decide if they are synonyms (words that have the same meaning) or antonyms (words that have the opposite meaning).

- 1) dreamed                      fantasized                      (synonym / antonym)
- 2) garbage                      rubbish                      (synonym / antonym)
- 3) regularly                      rarely                      (synonym / antonym)
- 4) improved                      worsened                      (synonym / antonym)
- 5) freedoms                      restrictions                      (synonym / antonym)

## EXERCISE 3

Match the items in the list with the pictures.

a) stars

b) accident

c) actress

d) angry

e) watch

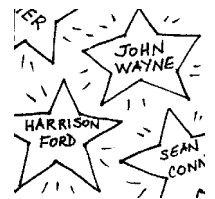
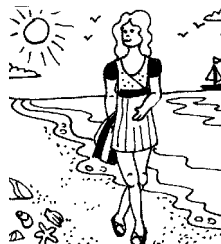
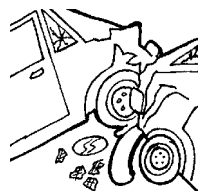
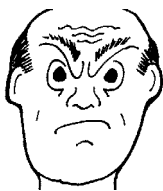

1)

2)

3)

4)

5)

---

## EXERCISE 4

1) Do you think celebrities have the right to their privacy? Should there be a separate set of laws designed to protect people who live very public lives?

### EXERCISE 5

Find the correct ending for each sentence according to the information in the story. Place the letter beside the correct beginning.

- |  |                                 |
|--|---------------------------------|
| 1) ___ Being famous means                    | a) to enjoy privacy.            |
| 2) ___ It's hard for famous people           | b) they are being photographed. |
| 3) ___ Most paparazzi                        | c) people recognize you.        |
| 4) ___ Victims of paparazzi often don't know | d) to restrict the paparazzi.   |
| 5) ___ Laws have been passed                 | e) carry cameras.               |

### EXERCISE 6

Combine half the word from column A with half a word from column B to form a word found in the article.

- |    | A     | B        |          |
|----|-------|----------|----------|
| 1) | reco  | brities  | 1) _____ |
| 2) | cele  | tive     | 2) _____ |
| 3) | photo | acy      | 3) _____ |
| 4) | nega  | gnize    | 4) _____ |
| 5) | priv  | graphers | 5) _____ |

### EXERCISE 7

The words below are hidden in the word find puzzle. Can you find them? Circle the word once you find it.

MOVIE STAR LAWS	PRIVACY MAGAZINES	CAMERA FILM	AUTOGRAPHS DIGITAL	PICTURES STALK					
M	R	I	O	F	I	L	M	L	A
A	O	Q	P	R	S	A	I	H	U
G	G	V	R	N	L	A	W	S	T
A	V	C	I	M	N	E	S	P	O
Z	C	O	V	E	L	J	H	I	G
I	A	H	A	J	S	V	M	C	R
N	M	I	C	K	T	T	L	T	A
E	E	W	Y	V	A	H	A	U	P
S	R	R	D	F	L	L	B	R	H
C	A	L	U	T	K	D	C	E	S
D	I	G	I	T	A	L	C	S	I

# ANSWER KEY

## EXERCISE 1

- 1) d
- 2) a
- 3) e
- 4) b
- 5) c

## EXERCISE 2

- 1) synonym
- 2) synonym
- 3) antonym
- 4) antonym
- 5) antonym

## EXERCISE 3

- 1) d
- 2) b
- 3) c
- 4) e
- 5) a

## EXERCISE 5

- 1) c
- 2) a
- 3) e
- 4) b
- 5) d

## EXERCISE 6

- 1) recognize
- 2) celebrities
- 3) photographers
- 4) negative
- 5) privacy

## EXERCISE 7

M				F	I	L	M		A
A	O		P						U
G		V	R		L	A	W	S	T
A			I					P	O
Z	C		V	E				I	G
I	A		A		S			C	R
N	M		C		T	T		T	A
E	E		Y		A		A	U	P
S	R				L			R	H
	A				K			E	S
D	I	G	I	T	A	L		S	

Copyright © 2005 FULL BLAST Productions

IN CANADA

FB Productions  
Box 408  
Virgil, Ontario  
L0S 1T0

IN THE UNITED STATES

FB Productions  
1623 Military Road #370  
Niagara Falls, New York  
14304-1745

Phone: 905-468-7558

Fax: 905-468-5706

E-mail: fbp@cogeco.ca

Website: www.fullblastproductions.com

Photocopying rights are granted to the individual teacher or the single school purchasing the materials. A copy of this book purchased by an individual teacher is that teacher's property and can travel with her from school to school. A single copy of this book may not be kept at a resource center and used to service several schools. To be entitled to copy this book, a teacher in the school or the school itself must own an original copy. Please respect copyright.

### **Library and Archives Canada Cataloguing in Publication**

**DeRocco, David, 1961-**

**Talk modern : stories to build a modern vocabulary /  
David DeRocco.**

**ISBN 1-895451-58-2**

**1. English language--Textbooks for second language  
learners. 2. Vocabulary. I. Title.**

**PE1449.D468 2005**

**428.6'4**

**C2005-906652-0**

Printed in Canada